

Spiralgrip 200 FS Easy-Loader

Turntable Stretch Wrapping Machine for up to 25 pallets per hour

High performance, cost effective, easy to use and economic film use

for economically wrapped loads

Power-Pre-Stretch-System



for maximum flexibility & safety

Modular Spiralgrip Concept

Features and Benefits

The Spiralgrip 200 FS model is the first of a new generation of stretch wrapping machines that can offer a PPS or Power Pre-stretch system of 260% with the infinitely variable film-tension control which reduces film costs and usage drastically. Simplicity is the key, and the FS turntable with the easy loading design of the turntable makes it very simple to use pallet hand trucks and also for forklifts to load the turntable. No loading ramp is needed saving effort and floor space and making wrapping fast, easy and simple to perform.

Adjustable Programming for maximum productivity and flexibility the load wrapping parameters, film carriage speed, turntable speed, film lay-on tension etc can all be set and adjusted from the integrated control panel. Machine safety is also important, with the film carriage located inside the machine tower, and the interlocked access door makes film loading simple and easy. Operators thus can work efficiently and safely with the machine

The Spiralgrip series is supported by Signode in Europe. Consumables, service and spare parts are readily available, please contact your local SIGNODE partner.

 **SIGNODE**[®]

An ITW Company

MACHINES

SEMI-AUTOMATIC

Spiralgrip 200 FS Easy-Loader

Turntable stretch wrapping machine for palletized loads

Easy film reloading by, film roll drop-in system



Easy pallet handling loading for hand trucks & forklifts



Power Pre-stretch (PPS) - of up to 260%

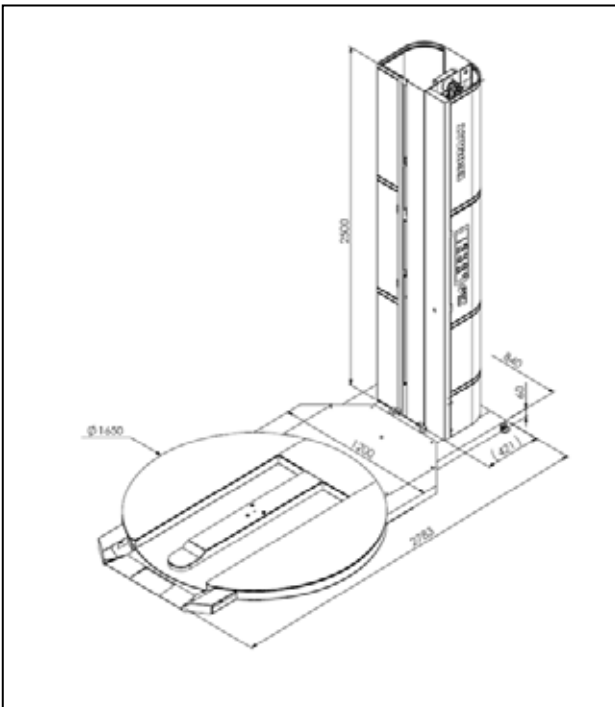

Technical Data

Capacity: 15-25 pallets / hour depending on wrap programme selected and load

Pallet load dimensions (mm)

L x W: max. 1.200 x 1.200

Height: max. 2.200 mm incl pallet

Weight: max. 1.200 kg

Transport dimensions (mm)

L x W x H: 2.600 x 1.800 x 1.200 mm approx.

Weight: 430 kg approx.

Film reel

Width: 500mm

Diameter max: 260mm

Core diameter: 76mm

Film thickness: 17-30µm (for PPS system)

Turntable Ø: 1.650 mm

Turntable height: 80 mm

Turntable speed: Variable from 2 to 12 rpm

Electrical Specification

Power requirement: 0,5 kVA max.

Voltage: 230 V, 1 Ph, 50 Hz

Control Voltage: 24 V DC

Options: 2m diameter turntable, Pit foundation template, load stabilizer.

The company reserves the right to make technical changes without prior notification

 **SIGNODE**[®]

An ITW Company

E-011074

MACHINES

SEMI-AUTOMATIC