

# LBX 2330

## Operatorless strapping machine

New generation. Fully automatic light duty operation.



### Jam-resistant technology

Patented LBX strapping head provides industry-leading packaging reliability.

### High speed strapping

Fast strapping cycle – up to 70 straps per minute – increases productivity potential.

### Dual direction strap loading

Strap loads from either direction eliminating down time and waste strap.

### Automatic cut-off and re-feed

Option to include patented feature which ejects mis-feeds and re-threads strap automatically.

### Variable speed conveyer

Standard variable speed reversible conveyer integrates easily into existing conveyer system.

### Low maintenance

Easy access, 40% less components and 'tool-free' service mean lower costs.

**SIGNODE**<sup>®</sup>

An ITW Company

INDUSTRIES

PACKAGING SYSTEMS

# LBX 2330

## Operatorless strapping machine

Fast, reliable and easy integration into automated production

### Function and operation

The Signode LBX 2330 brings high speed, fully automatic strapping to light duty packaging applications. With cycle times of up to 70 straps per minute, plus a range of advanced features, designed to eliminate unplanned downtime, LBX 2330 is the machine to achieve maximum productivity potential. And with 40% fewer components, compared to previous models, plus the elimination of wear parts, such as drive belts and clutches, with the LBX 2330, Signode have created a strapping machine that combines ease of operation with low cost of ownership.

### LBX 2330 Specifications

Cycle rate:	up to 70 straps per minute (subject to pack and chute size).
Max. pack weight:	45 Kg
Strap tension:	Adjustable from 10 N to 270 N
Strap size:	5 mm to 6 mm Polypropylene strap
Electrical requirements:	208 Volt, 60 Hz; 230 Volt, 60 Hz; 460 Volt, 60 Hz; 575 Volt, 60 Hz
Weight:	272 Kg

### LBX 2330 Options

- Single compression bar: 500 N at 6 bar
- Low strap indicator – warning light alerts operator when strap runs low/has run out, or if a malfunction occurs.
- EZ height adjustable leg kit (660 mm to 1015 mm)
- Automatic strap cut off and re-feed
- Conveyor interlock kit

### LBX 2330 Machine range

In addition to the LBX 2330, two automatic operator controlled versions are also available, the LBX 2300 and LBX 2000.

### Worldwide customer service

As a global product, consumables, service and other parts back up is available from Signode distributors and partners worldwide.

### Unmatched simplicity

LBX 2330 has 40% fewer parts, plus no drive belts or clutches. This combined with tool-free maintenance features, such as hot knife removal and jam-resistant technology make it easier to operate, with lower ownership costs.

### Easy accessibility

The strap path is full accessible. No tools are required. Just raise the table top and lift guide for access to the strap path. It's that simple!

### Dual direction strap feed

The strap coil can be run off from either direction, which eliminates downtime and strap waste that results from incorrect strap loading.

### Automatic cut-off and re-feed option

Patented Signode technology that automatically ejects mis-fed strap, then re-threads and continues strapping without any operator intervention.

### Variable speed conveyor

The LBX 2330 features a standard variable speed conveyor that easily integrates with existing conveyor lines enabling fast set up and operation.

### Tool-free conveyor removal

Conveyors can be quickly removed, without the use of tools for inspection and maintenance.

### Out of strap feature

Automatically ejects the remaining strap tail at the end of each coil, eliminating the downtime required to remove excess strap in the machine.

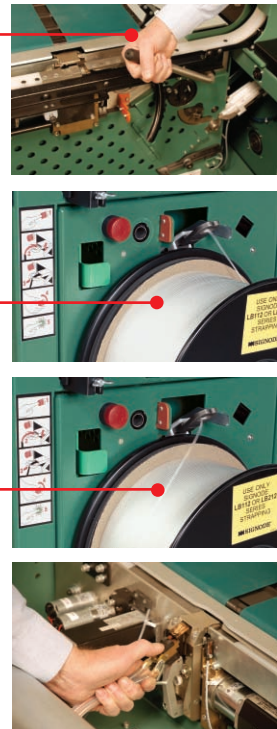

LBX 2330 Chute inner dimensions

A	B
510 mm	380 mm
710 mm	510 mm
840 mm	760 mm
1220 mm	510 mm

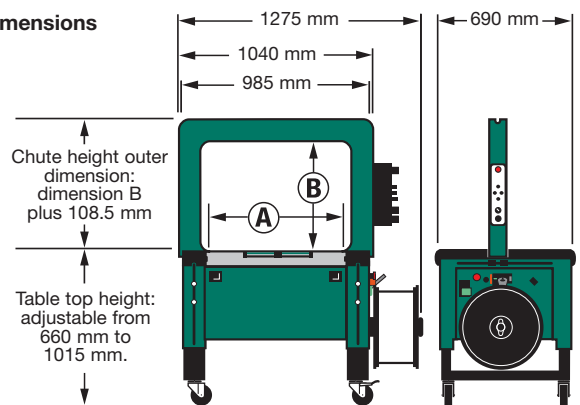

### SIGNODE BVBA

Ikaros Park, Ikaroslaan 33, 1930 Zaventem, Belgium  
Tel. 00800 3000 3131 oder +32 271 636 60  
Fax. 00800 4000 4141  
E-Mail: central\_uk@signode-europe.com



www.signode.com

An ITW Company  
© Signode 2007

PXXX E 12/07  
Printed in the U.K.

Signode has a policy of continuous product development and reserves the right to alter specifications at any time without prior notice.